



RAIU-1000-01
SHEET 1 of 11
Issue No.. E
MoD ref.. -

DECLARATION OF DESIGN AND PERFORMANCE

RAIU-1000-01-DDP

Radar Adaptor Interface Unit Telephonics RDR-1500 series

Name and Address of Manufacturer:	Real-Time Vision Ltd. 21 Hornsby Square Laindon Essex. SS15 6SD United Kingdom www.Real-Time-Vision.com
Description:	Radar Adaptor Interface Unit adapting signals from the Telephonics RDR1500 Series Radar into a form suitable for display on an AVDU series Monitor. Mounted to rear of a suitable modified AVDU series monitor. The unit derives its power from the host Monitor and the Radar Interface unit.
Identification (Drawing/Part Number):	RAIU-1000-01
Modification Standard (Issue)	Mod Strike 0
GA, Drawing or MRI Reference:	RAIU-1000-01-GA
Other Relevant Drawings:	See Table below
Weight and Overall	Mass: 1kg
Dimensions: (Approx)	Height: 120mm Width: 216mm including flanges Depth: 37mm not including connectors
Electrical Power Requirements:	+5V from Radar Interface Unit +12V from the host Monitor Dissipation ~10W
Details of Associated Approvals:	As listed herein
Applicable Manuals (Service. Overhaul, Wiring etc.):	See table below
Qualification Test Reports:	D0160D Test Report No. N/A See table below



RAIU-1000-01
SHEET 2 of 11
Issue No.. E
MoD ref.. -

DECLARATION OF DESIGN AND PERFORMANCE

Stress Report	SR No. N/A (Enclosed box, non hazard)	
Environmental Conditions	Altitude	To 25,000ft
	Temperature	Stand-by -30°C to +70°C Operating -25°C to +55°C Storage -30°C to +80°C
	Humidity	@ +20°C to 80% Non Condensing
	Waterproofed	No - To be cabin mounted.
Other Relevant Reports	N/A	
Limitations:.	As listed herein	

I hereby certify that the above information is accurate. Real-Time Vision cannot accept responsibility for the satisfactory operation of equipment used outside the conditions given above.

Signed:..... *AJMSuggan*

Whilst care has been taken to provide as much detail as possible for use of this product it cannot be relied upon as an exhaustive source of information. This product is for use by suitably qualified persons who understand the nature of the work they are doing and are able to take suitable precautions and design and produce a system integration that is safe and meets regulatory requirements.



RAIU-1000-01
SHEET 3 of 11
Issue No.. E
MoD ref.. -

DECLARATION OF DESIGN AND PERFORMANCE

APPLICABLE DOCUMENTS

REFERENCE	TITLE	REV	DATE
RAIU-1000-01-ICD	Interface control Drawing	D	
RAIU-1000-01-GA	GA, Drawing or MRI Reference:	B	
RAIU-1000-01-ATP	Acceptance Test Procedure for 20 inch LCD Monitor	B	
RAIU-1000-01-OPS	Operator Manual	B	
RAIU-1000-01-DDP	Declaration of design and performance	-	- see cover
RTCA DO-160D	Environmental Conditions and Test Procedures for Airborne Equipment	D + Ch 1 Ch 2 Ch 3	Jul 1997 Dec 2000 Jun 2001 Dec 2002
MIL-STD-704E	Transients	E	
MIL-STD-461E	EMI: conducted emission/ conducted susceptibility	E	
	Bendix King RDR 1500 series interface drawing		



RAIU-1000-01
SHEET 4 of 11
Issue No.. E
MoD ref.. -

DECLARATION OF DESIGN AND PERFORMANCE

EUROCAE/ED-14D /RTCA DO-160D compliance statement

DO-160D, Environmental Conditions and Test Procedures for Airborne Equipment Issued July-29-1997 Superseded DO-160C, Changes 1, 2 & 3 Prepared by SC-135 Standard procedures and environmental test criteria for testing airborne equipment for the entire spectrum of aircraft from light general aviation aircraft and helicopters through the “Jumbo Jets” and SST categories of aircraft. The document includes 25 Sections and three Appendices. Examples of tests covered include vibration, power input, radio frequency susceptibility, lightning, and electrostatic discharge. Coordinated with EUROCAE, RTCA/DO-160D and EUROCAE/ED-14D are identically worded.

DO-160D is recognized by the International Organization for Standardization (ISO) as de facto international standard ISO-7137.

This unit has been designed to meet the environmental conditions specified in RTCA/DO-160D, dated as indicated below.

Section	ECF Requirement	Current Design
4 – Temperature & Altitude	B2	Category A1 This unit is considered satisfactory for operation up to an altitude of 25,000 feet un-pressurised.
5 – Temperature Variation	B	Category C
6 – Humidity	B	Category A
7 – Operational Shocks & Crash Safety	Operational Shocks Constant Acceleration	Category B Operation 6g 11/ms Non operation 15g/11ms
8 – Vibration	B	Category R+U (equiv: DO-160C Helicopter –Test curve ‘N’, 1.5g p-p)
9 – Explosion Proofing	NR	N/A Category A Equipment located within the passenger cabin.
10 – Waterproofing	W By analysis no test required	Category W
11 – Fluid susceptibility	F	Category X
12 – Sand & Dust	D	Category D
13 – Fungus Resistance	F	N/A Category F
14 – Salt Spray	S	N/A Category X
Sections described below, which address the EMC requirements for aircraft, are called up in the Advisory Circular Joint (AC)/ Advisory Material Joint (AMJ) 20.1317 and the User Guide. They describe detailed test EMC requirements and test methods for each of the phenomena listed:		
15 – Magnetic Effect	A	Category A The unit has no perceivable effect when mounted within 460mm (18”) of an aircraft magnetic compass
16 – Power Input		Category B Not Applicable – unit is fed from the Radar and the monitor
17 – Voltage Spike	A	Category A Not Applicable – unit is fed from the Radar and the monitor



RAIU-1000-01
SHEET 5 of 11
Issue No.. E
MoD ref.. -

DECLARATION OF DESIGN AND PERFORMANCE

18 – Audio Frequency	A	Categories A + Z
19 – Induced Susceptibility	Z	Category Z
20 – RF Susceptibility (Radiated & Conducted)	Area C	Category U
21 – RF Emission	H	Category B
22 – Lightning Induced Transients	NR	Not considered
23 – Lightning Direct Effects	NR	Not considered
25 – Electrostatic discharge		
24 – Icing	NR	Category X

Solar radiation Para 4.10	Applicable	Applicable for the monitor only.
Design Para 6.1		Applicable
Test installation Para 6.2	Wiring	Applicable
	Bonding	Applicable
Emission of spikes on power leads EN2282 Para 6.4		Applicable
HIRF Para 6.10	LEVEL C AREA C	Applicable Condition for level C is already Covered by § 6.9 Chapter 20 and will not require more test or analyses.



RAIU-1000-01
SHEET 6 of 11
Issue No.. E
MoD ref.. -

DECLARATION OF DESIGN AND PERFORMANCE

DESIGN STATEMENT

The Radar Adaptor described herein has been designed using techniques, common parts and practices gained from the design and testing to RTCA DO-160 of other equipment in the AVDU series. The principle areas of similarity are:

Housing Construction

The housing is constructed from machined aluminium. The front case has a groove around the perimeter that matches an "O" ring sealing the unit the rear case of the host monitor. This construction improves EMC and the resistance to the ingress of moisture.

Component retention

All major components and assemblies are secured to the chassis using a combination of metal and insulating nylon screws.

Components that may become loosened by vibration, such as plug in components and links, are secured using non-conductive silicon sealant or epoxy.

Screws secure the case to the host monitor.



RAIU-1000-01
SHEET 7 of 11
Issue No.. E
MoD ref.. -

DECLARATION OF DESIGN AND PERFORMANCE

General Description

This specification applies to the Radar Adaptor Interface Unit RAIU-1000-01 and its variants. The adaptor unit is designed as an upgrade to an existing AVDU series Display and is mounted on the rear face of the host monitor using an adaptor plate that locates on the existing pairs of side mounting holes on the monitor. The unit interfaces between the Bendix King RDR 1500 Radar and an AVDU series display by modifying the signals from the radar into a form suitable for display on the monitor. The unit houses an alarm circuit for the Radar providing a status indicator output that may be presented to the operator.

This Unit contains:

- Power input filter and Power supply module
- Radar Adaptor Panel Electronic Circuit (PEC)

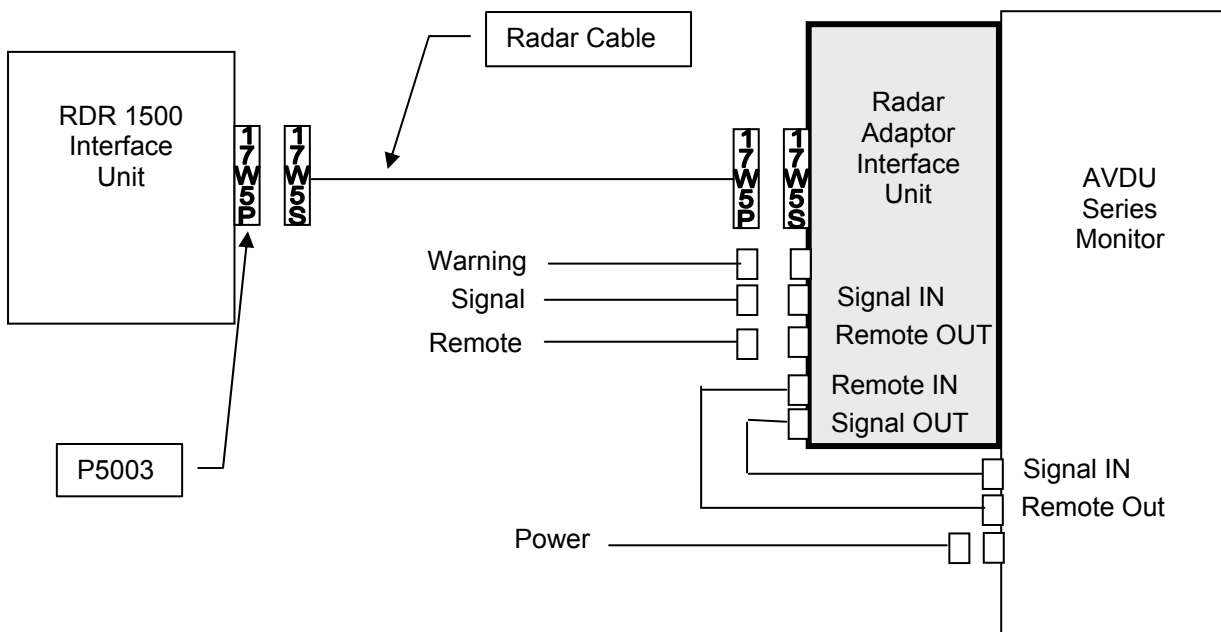



RAIU-1000-01
SHEET 8 of 11
Issue No.. E
MoD ref.. -

DECLARATION OF DESIGN AND PERFORMANCE

Miscellaneous	
Safety	The design of the monitor is such that any failure will not result in a hazardous condition and provides fail-safe features for safety of personnel during the installation, operation, maintenance and repair
Input protection	Short circuit to Chassis of any input will not damage the equipment nor cause an unsafe condition.
Output protection	Short circuit to earth of any output will not damage the equipment nor cause an unsafe condition.
Bonding	All metallic parts are bonded with a max resistance between any two parts of 0.5Ω.
Earthing	All D.C. neutral or negative connections as well as signal returns are brought-out via the external connectors and separated from each other. (exception made for R.F. circuitry)
Insulation Resistance	Insulation between any two points of this equipment not electrically connected to each other is at least 20M ohms. This measurement is made on a complete item of equipment.
Cooling	Cooling of the equipment is by natural convection. The installer must ensure that the case temperatures are not exceeded.

DESIGN AND PRODUCTION	
Components, materials and processes	Standard parts are used wherever possible. As a general rule, the use of non-approved components is avoided. Where this is not possible, components are selected to meet the conditions of the particular specification of the equipment.
Metallic materials	Metallic materials used for manufacturing the equipment are consistent with the grades selected by the national and international aviation standards. The materials used are adequately protected against corrosion of any origin by using only qualified methods that are sufficiently efficient considering the environmental conditions to be found on the aircraft.
Flammable materials	Materials employed in the equipment design and manufacturing do not promote combustion. In event of fire the metallic and glass construction of the case does not sustain nor support combustion and no hazardous quantities of toxic or noxious (e.g. smoke) products will be distributed in the crew / cargo compartments.
Finishing	Equipment external surfaces are finished Matt Black
Interchangeability	All parts built with the same part number (P/N) or drawing number are functionally and dimensionally interchangeable with each other.
Identification and marking	Information on the equipment identification label is as follows: <ul style="list-style-type: none"> • Manufacturer's name • Item description • Part Number • Serial Number • Date of Manufacture • Identification Firmware revisions (where applicable)



RAIU-1000-01
SHEET 9 of 11
Issue No.. E
MoD ref.. -

DECLARATION OF DESIGN AND PERFORMANCE

Controls

None:

Electrical

The unit derives its power from the RDR1500 Series Radar and from the host AVDU series monitor.

Power rail	Source	Current
+5VDC	RDR 1500	
+12V DC	AVDU series Monitor	

Maintenance

There are no user serviceable parts inside the unit.

1st Line maintenance – replacement of faulty unit (With attached monitor)



RAIU-1000-01
SHEET 10 of 11
Issue No.. E
MoD ref.. -

DECLARATION OF DESIGN AND PERFORMANCE

Handling Precautions

Handling of the unit should be in compliance with Real-Time Vision's handling principles.

- 1) Be sure to turn off power supply when inserting or disconnecting the input connectors.
- 2) Wipe off water or fluid droplets immediately. Long contact with water or other fluids may cause discoloration or spots.
- 3) Since CMOS LSI is used in this module, take adequate static electricity precautions and ensure correct human earth bonding when handling.
- 4) Do not open nor modify the Assembly.
- 5) At the insertion or removal of the Power and Signal Interface Connector, ensure that the sockets are free from debris and be sure not to damage the Interface pins



RAIU-1000-01
SHEET 11 of 11
Issue No.. E
MoD ref.. -

DECLARATION OF DESIGN AND PERFORMANCE

Safety

Sharp Edge Requirements

There are no sharp edges or comers on the unit that could cause injury.

Materials

Toxicity

There are no carcinogenic materials used anywhere in the display module. Where toxic materials are used, they will be reviewed and approved by the responsible ADT Toxicologist.

Flammability

All components including electrical components that do not meet the flammability grade UL94-V1 in the module will complete the flammability rating exception approval process. The PECs (Panel Electronic Circuit) boards will be made from material rated 94-V1 or better. The actual UL flammability rating will be printed on the printed circuit board where appropriate.

Capacitors

Where polarized capacitors are used in the unit, provisions will be made to keep them from being inserted backwards.

Hazardous Voltages

Any point exceeding 42.4 volts meets the requirement of the limited current circuit. The current through a 2K Ω resistance is less than $0.7 \times f$ (kHz) mA.

LIMITATION OF LIABILITY

The manufacturer's liability for damages to customer or others resulting from the use of any product supplied hereunder shall in no event exceed the purchase price of said product.

IMPORTANT USAGE NOTE

This equipment is for use by developers and integrators, the manufacturer accepts no liability for damage or injury caused by the use of this product. It is the responsibility of the developer, integrators or other user of this product to:

- Ensure that all necessary and appropriate safety measures are taken.
- Obtain suitable regulatory approvals as may be required.
- Check power settings to all component parts before connection.

Disclaimer

Real-Time Vision reserves the right to make changes to this document and the product which it describes without notice. In addition, Real-Time vision. shall not be liable for technical or editorial errors or omissions made herein; nor for incidental or consequential damages resulting from the furnishing, performance, and use of this product.

This product shall not be used for or in connection with equipment that requires an extremely high level of reliability, such as life critical systems, nuclear power control equipment and medical or other life support equipment. Real-Time Vision. takes no responsibility for damage caused by improper use of this product which does not meet the conditions for use specified in this specification sheet.