

AVDU-2606-02-03-OPS

Issue No.. A

Operators Manual



AVDU-2606-02-03-OPS

10.4" LCD Display



General Description

This manual applies to the 260mm (10.4") Colour TFT-LCD Display AVDU-2606-02-03.

The display supports the XGA (1027(H) x 768(V)) screen format and 16.7M colours (RGB 8/6-bits data) at high response speeds optimised for high-speed motion video typical in airborne surveillance applications. The display has been configured for automatic video detection and will select the first video or graphic input it detects with a valid signal feed.

The unit is fitted with a permanent NVG filter to allow operation in all lighting conditions and at night with out compromising NVG operation.

This manual relates to the base operation man machine interface version. Upgrades to the man machine interface are indicated in a firmware upgrade identification plate at the rear of the unit and on the On screen Display (OSD)

This manual relates to the following man machine interface versions:

Control system	Version 1.0 (Baseline configuration)
On Screen display (OSD)	Version 1.3 (Version displayed in the OSD)

Equipment connections

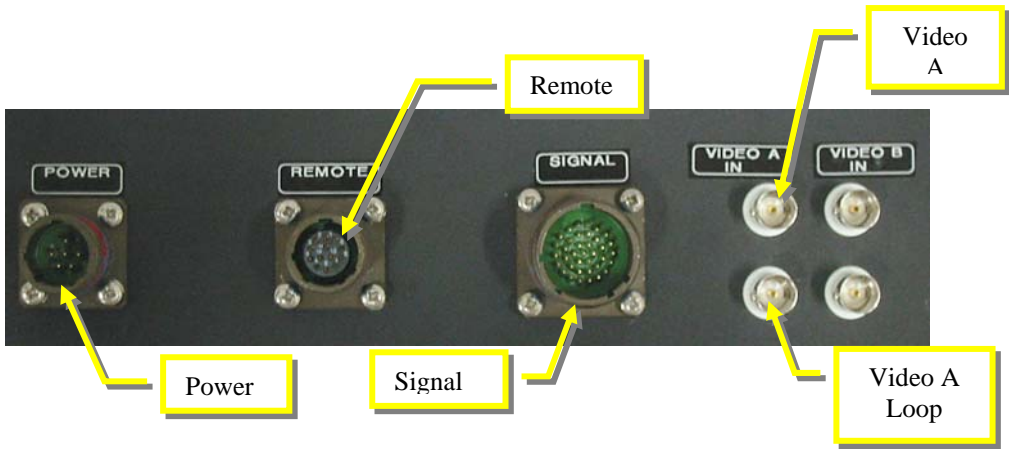

*Note: The unit will select the first video or graphic input it detects after power up – if no input is detected the unit will go into a “Standby” mode.

See the ICD for a list of available connections and pin-outs.

This unit will automatically select from the following input ports:

- Composite Video (VIDEO A BNC or Signal connector)
- Y/C Video (S-Video) (Signal connector)
- RGB Video (Sync on Green) (Signal connector)
- Graphics (RGBHV) (Signal connector)

The unit is set internally to decode RGB rather than Y, Cr, Cb component inputs.

Control Key Functions and legend



The Unit will power on when power is applied and the Power button is pressed in.

Note: The unit will auto power off (after several seconds) when there is no input detected on any of the video ports.

The brightness rotary control (left bottom) adjusts the display illumination and the associated key backlights. (This should be set to a low level at night when operating with NVG goggles)

CONT +/- will adjust the contrast of the currently displayed input.

FREEZE will freeze the currently displayed video input (it will have no function if the currently displayed image is a Graphic input.

VIDEO Selects Composite Video 1 (From the BNC on the back)

Pressing MENU down will display the on screen menu

The Menu, UP, Down, Left and Right keys operate the On-screen display menu system

The Menu will be removed from the screen when the MENU key is held down for more than 5 seconds.

The brightness of the control buttons is set by three parameters:

- The external Aircraft brightness/illumination bus (Where fitted)
- The position of the main rotary brightness control
- The control “offset” stored in the display non volatile memory

The offset is set with the up and down buttons when in graphic mode. This allows the setting of the button brightness to be adjusted up or down from the level set by the external brightness/illumination input or the front panel control.

Operator controls

The equipment configuration is controlled from a series of rotary controls and push buttons.



1. The Power switch and Brightness controls operate independently of the other controls.

Power – This control is a latching control and when pushed in will turn the display on. (The display will go into standby if no video input is detected after 10 seconds)

BRT – This rotary control adjusts the illumination level of the display.

2. There are no video or Graphic source select keys – the source is selected automatically.

3. The two contrast keys control the contrast of the displayed image. The Graphic contrast settings are stored separately from the VIDEO settings.

4. The Menu select key invokes the On Screen Menu Display (OSD) and selects the menu when held down for more than 5 seconds. To exit the menu press and hold the key for >5 seconds

5. The four direction keys have four modes depending on the current display mode.

MODE	Graphic	VIDEO	MENU/OSD
Down	Dim the brightness of the keys	Freeze and zoom in	DOWN
UP	Increase the Brightness of the keys	Freeze and zoom out	UP
LEFT	MAP Contrast -	Video Contrast -	LEFT
RIGHT	MAP Contrast +	Video Contrast +	RIGHT

On Screen Display (OSD) operation.



To turn on the OSD menu:

Press the MENU button for > 5 sec

Move to next icon:

Press the MENU button momentarily

Select options within icon menu:
is in yellow.

Use SEL UP/SEL DN buttons, the selected option

Increase/decrease setting:

Use +/- buttons (SEL RIGHT/LEFT)

Move selection left/right:

Use +/- buttons, the selected option is in green

To confirm the selection:

Use + button (SEL RIGHT)

To turn off the OSD Menu

Press the MENU button and hold for > five seconds
– this will store the user adjusted settings

On screen Display (OSD) functions

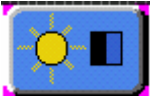

Brightness and Contrast :

The Brightness and contrast of the video and Map are independent

Brightness  Increase/decrease panel brightness level, total: 100 steps **(50)**

Contrast  Increase/decrease panel contrast level, total: 100 steps **(50)**

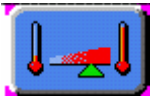

Colour Temperature : 9500K / **8000K** / 6500K / 5000K

Adjust the warmness of the image displayed. The higher temperature the cooler the image looks like. The lower temperature the warmest image looks.

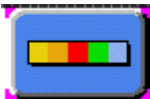

Video Adjustment : (DISPLAYED IN VIDEO MODE ONLY)

Colour:  adjust video colour level

Tint:  adjust video tint level (NTSC video only)

Sharpness:  adjust video image sharpness level

Picture Type Motion/Still/Normal Select different modes for different Videos
Motion mode – Good for dynamic scenes
Still mode – Steady and sharp image. For still picture displayed.

Normal mode – “Non-flicker” image. For general use

Video Type: DVD / VCR change bandwidth to match the source **(DVD)**

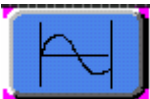

Frequency and Phase : (DISPLAYED IN PC MODE ONLY)

Frequency  Adjust the image horizontal size

Phase  Fine tune the data sampling position (adjust image quality)

Picture Type : Motion/Still/Normal
 Select still mode to getting a stable still picture displayed inside PIP window.

Select Normal mode to getting a better display quality for RGB video input
(MOTION)



Video System : Select video system and input signals
 AUTO

(DISPLAYED IN VIDEO MODE ONLY)

: automatic detection of NTSC and PAL system (not applicable in SECAM system)

(AUTO)
 NTSC / NTSC 4.43 : manual select NTSC system
 PAL / PAL M : manual select PAL system
 SECAM : manual select SECAM system

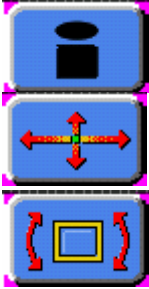







Status : Display graphic (DISPLAYED IN PC MODE ONLY)
 information: resolution and frequency

Position :
 Image up/down : Use SEL UP/SEL DN to move the image vertically
 Image left/right : Use +/- SEL RIGHT/LEFT to move the image horizontally
Rotation : Rotates the image from (DISPLAYED IN VIDEO MODE ONLY)
 landscape format to portrait format.



Picture in Picture : (DISPLAYED IN PC MODE ONLY)
 PIP Size : / 1 / 2 / 3 Select PIP window size: close, size 1, size 2 to size 24
 Do not set this to zero or no PIP will be displayed in PIP mode
 PIP Source : Select video source to be display in PIP window: **(Set to Auto)**
 Auto / Comp / Svid/YCbCr

Auto – automatic detection of Composite, S-video and Component
Comp – manual select composite video only
SVid – manual select S-video only
YCbCr/RGB – manual select component video only
 (YCbCr/RGB Internally selected)

Horizontal Position  adjust the position of the PIP window horizontally
 Vertical Position  adjust the position of the PIP window vertically
Advanced PIP Settings :
 Brightness  adjust the image brightness of the PIP window
 Contrast  adjust the image contrast of the PIP window
 Sharpness  adjust the image sharpness of the PIP window
 Tint  adjust the tint of the image of the PIP window
 Colour  adjust the colour of the image of the PIP window

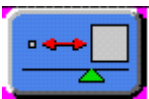

Video Scaling : (DISPLAYED IN VIDEO MODE ONLY)
 Use the UP and DOWN arrow keys to select the following scaling modes.
Normal
 Letterbox
 Letterbox with Subtitles
 Nonlinear Scaling Modes : Horiz Clipping / Horiz Offset / Horiz Stretch / Vert

Clipping / Vert Offset / Vert Stretch

Graphic

(DISPLAYED IN PC MODE ONLY)

Scaling

Modes

Use the up and down arrow keys to choose a scalar mode.

Use the + or - key to modify a following scalar parameters.

One to One :

Horizontal Pan



Vertical Pan



Fill Screen

: enable full screen expansion for lower resolution Image
(Default)

Fill to Aspect

: enable fill screen expansion for lower resolution image according to aspect ratio.

Nonlinear

Horiz Clipping / Horiz Offset / Horiz Stretch / Vert Clipping /

Scaling Modes

Vert Offset / Vert Stretch

:

Language : Select OSD menu language display

1. English **(Default)**
2. Danish
3. Chinese (Simplified)
- 4.

Video source : Select the input video signal

Analogue RGB / Component Video / **Composite Video** / S-Video

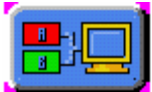





Utilities :

- User Setting : User Timeout adjust the OSD menu timeout period in a step of 5 seconds
 (No user adjustment possible – setting will be overridden)
- DPMS Disable / **Enable** the DPMS function
 When enabled the screen will display an error message when no input is present on the selected image source. The display will go into standby after a short period if there continues to be no input. The display will “wake up” if an image source returns.
- Display Input Disable /Enable the input source name on screen **(Disabled by default)**
- Auto Source Select : Off - Disable auto source select function.
 Low - Auto source select enable ONLY in power up.
 High - Auto source select ALWAYS enable.
 Set to **OFF by Default** – screen will display an error message when no input is present)
- Gamma: 1.0 **(Default setting)**
 1.6
 2.2
- Video Port Select Select “Port 1” or “Port 2” of the source Composite/SVideo/YCbCr
(Do not adjust these settings)

OSD Setting :

- OSD Horz Position :  move the OSD menu horizontally
- OSD Vert Position :  move the OSD menu vertically
- OSD Background : **Translucent** / Opaque
- OSD Rotate : **Normal** / Rotate
- Freeze Frame : Freeze the image (use “+” button)
- Zoom : Zoom level : enable the zoom in function on the image displayed.
 Use “+” Right button to zoom in the image.
 Use “-“ Left button to decrease the zoomed image.
- Horizontal Pan 

Vertical Pan



Direct Access #1: Define the hot key function(Right "+" and Left"-") for one of the following adjustments : Brightness / Contrast / Volume / Freeze / Zoom / Video Source* / PIP (Not implemented)
(Automatically set to Contrast)

Direct Access #2: Define the hot key function ("SEL UP" and "SEL DN") for one of the following adjustments : Brightness / Contrast / Volume / Freeze / Zoom / Video Source* / PIP
(Automatically set to key Brightness offset) (Not implemented)

Display Orientation : **Normal** / Horizontal Inverse /

Vertical Inverse / Inverse

Calibrate RGB Gain : Colour Calibration

(DISPLAYED IN PC MODE ONLY)

Load Factory Defaults : Recall factory default settings.

* By pressing the hot key, the source is in sequence of Analogue

RGB/Composite Video/S-Video/Component Video.



Volume : Not Implemented

Adjust the audio volume level (functions only if the audio add-on installed)



Exit menu – do not use this to exit – Press and hold the Menu key for > 5 seconds and the settings will be correctly stored.

(applies to V1.30 OSD firmware)

The OSD settings chosen will be stored in memory. The OSD menu can be cleared from the screen by holding the Menu button and waiting for the preset time period. Exiting the Menu in this way will allow the system to store the changed parameters and return to the normal operating mode. Moving the selection bar to the EXIT icon pressing the + (Right) button will exit the menu will cause the menu system to malfunction.

A note on Brightness

The front panel brightness control adjusts the illumination level coming from the display unit. It may be adjusted to match the background illumination level present in the aircraft and may be set to very low levels for night operation and high levels for day operation. Care should be taken not to leave the unit powered at high brightness levels when in a static or training mode as high power is drawn by the unit and overheating may occur. There is an independent “brightness” secondary control on the OSD for both the video and the Graphics/map input. This sets the video level of the video or graphic source. It is factory set to its midpoint (50) and it should not be normally necessary to adjust this on a day to day basis.

Contrast.

The contrast is normally adjusted using the “Contrast” key in graphic or video mode. Pressing either these keys will display a contrast bar in the centre of the screen. Pressing the keys or holding them will adjust the contrast + or -. The contrast is factory set to its midpoint (50) It should not be necessary to adjust this on a day to day basis unless the contrast level from the sensor video is poor (It is usually better to adjust the sensor settings rather than the “normalised” display. (Holding the key will auto repeat for rapid value change) The contrast settings for the graphic and the video are independent and are stored separately.

A note on the Direct Keys

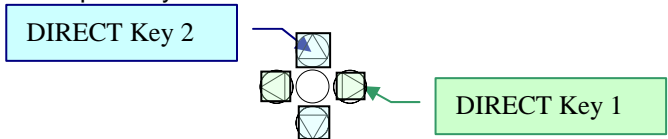

The function of the four direct keys cannot be re-programmed using the OSD

Utilities menu. 

Direct Key 1

Direct key one is programmed in the factory to contrast and It is not possible for this to be changed by the user.

Direct Key 2

The function of these keys is programmed in to the backlight brightness of the control pushbuttons.

TROUBLESHOOTING

General

A general guide to troubleshooting the flat panel display system it is worth considering the system as separate elements, such as:

- External Equipment; PC settings, video format
- Display Panel (Menu setup, cabling, connection, panel, PC settings)
- Backlight (inverter, cabling, backlight tubes)
- Computer system (display settings, operating system)

Through step-by-step cross checking with instruction manuals and a process of elimination to isolate the problem it is usually possible to clearly identify the problem area.

Removing power from the system (Turning the Power switch on the front panel to OFF) may clear a system lockup or return the settings to their default condition.

No image:

- If the panel backlight is not working it may still be possible to just see some image on the display.
- A lack of image is most likely to be caused by incorrect connection, lack of power, failure to provide a correctly formatted signal or incorrect graphic card settings.

Image position:

If it is impossible to position the image correctly, i.e. the image adjustment controls will not move the image far enough, then test using another graphics card. This situation can occur with a custom graphics card that is not close to standard timings or if something is in the graphics line that may be affecting the signal such as a signal splitter (please note that normally a signal splitter will not have any adverse effect).

Image appearance:

- A faulty panel can have blank lines, failed sections, flickering or flashing display
- Incorrect graphics card refresh rate, resolution or interlaced mode will probably cause the image to be the wrong size, to scroll, flicker badly or possibly even no image.
- Internal jumper settings are set at the factory. Incorrect internal jumper settings on the internal controller card may cause everything from total failure to incorrect image.

Continued failure:

If unit after unit keeps failing consider and investigate whether you are short circuiting the equipment or doing something else seriously wrong.

Generally after common sense issues have been resolved we recommend step-by-step substitution of known working parts to isolate the problem.

Handling Precautions

Handling of the Display should be in compliance with Real-Time Vision's handling principles.

- 1) Since front window is an optical assembly and is easily damaged, observe precautions in order not to scratch it.
- 2) Be sure to turn off power supply when inserting or disconnecting the input connectors.
- 3) Wipe off water or fluid droplets immediately. Long contact with water or other fluids may cause discoloration or spots.
- 4) When the front window surface is soiled, wipe it with absorbent cotton or other soft cloth.
- 5) Since the panel is made of polycarbonate or glass, it may break or crack if dropped or bumped on hard surface.
- 6) Since CMOS LSI is used in this module, take adequate static electricity precautions and ensure correct human earth bonding when handling.
- 7) Do not open nor modify the Assembly.
- 8) Do not press the front window sheet in any direction.
- 9) At the insertion or removal of the Power and Signal Interface Connector, ensure that the sockets are free from debris and be sure not to damage the Interface pins
- 10) After installation of the Display into a mounted position, do not twist nor bend the Display even momentary. When designing a suitable mounting, it should be taken into consideration that no bending/twisting forces are applied to the Display from outside. Otherwise the TFT -LCD module or backlight may be damaged.

Manufactured and Published in the United Kingdom
© 2005 Real-Time Vision Limited